

# Torque motors RSM - P - 36 - 641 - ...

## Notes:

1. Motor has peak torque at peak current  $I_p$  (2...3 sec)
2. Max temperature of rotor  $70^{\circ}\text{C}$ .
3. The stator has build-in threshold sensor for temperature  $120^{\circ}\text{C}$ .
4. Max. input pressure of liquid fluid - 1,1 bar
5. All data are subject to change without notice
6. All data tolerance  $\pm 10\%$ .

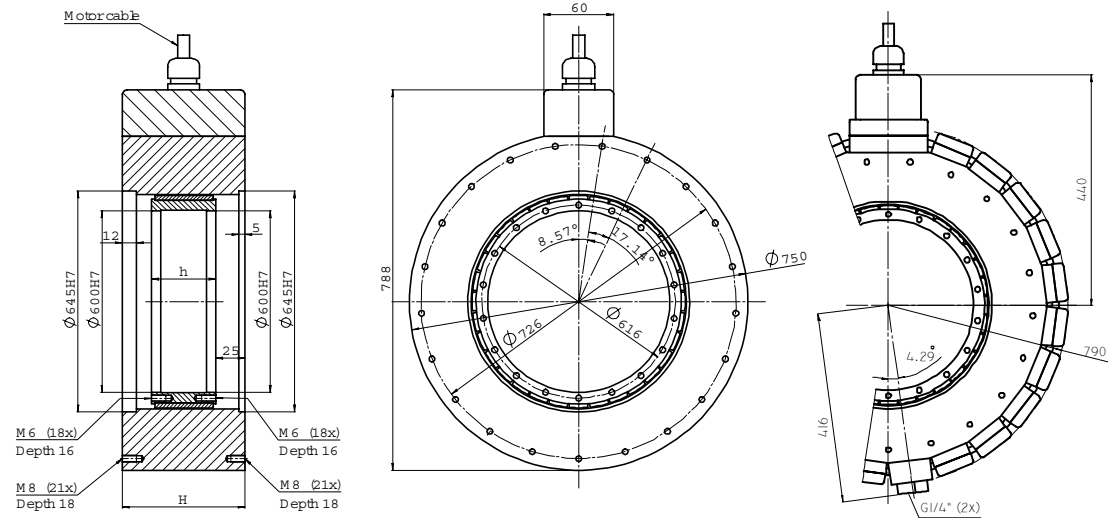

Overall and join dimensions

with water cooling

Parameter		Unit	RSM-P-36-641*25		RSM-P-36-641*50		RSM-P-36-641*75		RSM-P-36-641*100				RSM-P-36-641*150			
			B	B	B	B	A	B	A	B	A					
Peak torque (coil at 20°C)	Mp	Nm	1143	2285	3428	4571		6856								
Continuous torque (coil at 120°C), water cooling	Mw	Nm	918	1835	2753	3671		5506								
Continuous stall torque (coil at 120°C), water cooling	Ms	Nm	717	1434	2151	2868		4302								
Continuous torque (coil at 120°C), air cooling	Ma	Nm	470	940	1410	1880		2821								
Detent torque	Md	Nm	4.6	9.1	13.7	18.3		27.4								
Rotor inertia	Jr	kgm <sup>2</sup>	0.77	1.54	2.31	3.08		4.62								
Number of poles pairs	P		56	56	56	56		56								
Stator height	Hs	mm	80	105	130	155		205								
Motor mass <sup>1</sup>	m	kg	101.2	143.8	186.4	228.9		314.2								
Peak power dissipation (coil at 20°C)**	Pp	W	5003	7561	10149	12745		17942		18016						
Continuous power dissipation (coil at 120°C), water cooling**	Pw	W	3075	4601	6155	7715		10843		10907						
Continuous power dissipation (coil at 120°C), air cooling**	Pa	W	822	1171	1540	1914		2666		2706						
Coolant flow for temperature difference 5°C by power Pw**	Cf	L/min	2.2	3.3	4.4	5.5		7.8		7.8						
Recommended supply voltage DC	Us	V	600	600	600	600		600								
3 phases winding combination			<b>BS</b>	<b>BT</b>	<b>BS</b>	<b>BT</b>	<b>BS</b>	<b>BT</b>	<b>BS</b>	<b>BT</b>	<b>AS</b>	<b>AT</b>	<b>BS</b>	<b>BT</b>	<b>AS</b>	<b>AT</b>
Maximum velocity at Mp and Us (Coil at 20°C)	Np	rpm	87	157	41	77	25	49	17	35	30	57	8	21	17	36
Maximum velocity at Mw and Us (Coil at 20°C)	Nw	rpm	103	183	49	90	30	58	21	42	36	67	12	26	22	43
Maximum velocity at Ma and Us (Coil at 20°C)	Na	rpm	138	241	67	121	44	79	32	59	50	90	19	38	32	59
Peak current at Mp and N=0	Ip	Arms	29.7	51.4	29.7	51.4	29.7	51.4	29.7	51.4	44.5	77.1	29.7	51.4	44.5	77.1
Continuos current at 120°C, water cooling at Mw and N=0	Iw	Arms	23.0	39.9	23.0	39.9	23.0	39.9	23.0	39.9	34.6	59.9	23.0	39.9	34.6	59.9
Continuos current at 120°C, air cooling at Ma and N=0	Ia	Arms	11.3	19.6	11.3	19.6	11.3	19.6	11.3	19.6	17.0	29.4	11.3	19.6	17.0	29.4
Motor constant (coil at 20°C)	Ko	Nm/√W	20.4		32.8		42.3		50.2				63.4			
Back EMF constant (*) (peak phase-phase)	Ku	V/(rad/s)	33.9	19.6	67.7	39.1	101.6	58.7	135.5	78.2	90.3	52.2	203.2	117.3	135.5	78.2
Electrical resistance at 20°C (*)	R	Ohm	2.77	0.92	4.27	1.42	5.77	1.92	7.28	2.43	3.23	1.08	10.28	3.43	4.57	1.52
Electrical inductance (*)	L	mH	23.1	7.7	46.2	15.4	69.3	23.1	92.4	30.8	41.1	13.7	138.6	46.2	61.6	20.5

<sup>1</sup> terminal-terminal value    \*\* for connection star    <sup>1</sup> Sum rotor and stator mass